

# WSR250 nicht selbstzentrierend not self-centering

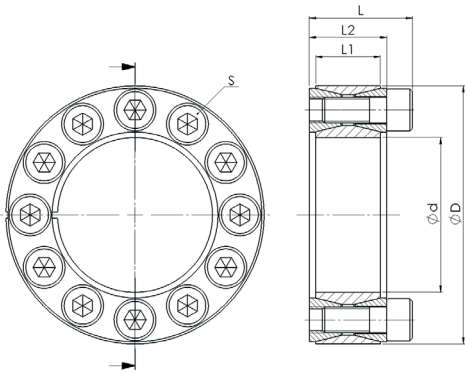

**Material:**  
Stahl  
**Toleranz:**  
Welle: h11  
Nabe: H11  
**Oberflächenrauigkeit:**  
Rt max. 16 µm

**Material:**  
Steel  
**Tolerance:**  
Shaft: h11  
Hub: H11  
**Surface roughness:**  
Rt max. 16 µm

WSR250		Abmessungen Dimensions			Flächenpressung Surface pressure		ISO 4762 - 12.9		
Ød x ØD	TKN	L	L1	L2	P <sub>w</sub>	P <sub>N</sub>	S	TA	M
	[Nm]	[mm]			[N/mm <sup>2</sup> ]			[Nm]	[kg]
19x47	298	26	17	20	286	116	8x M6	19	0,2
20x47	313	26	17	20	272	116	8x M6	19	0,2
22x47	345	26	17	20	247	116	8x M6	19	0,2
24x50	424	26	17	20	255	123	9x M6	19	0,25
25x50	441	26	17	20	245	123	9x M6	19	0,25
28x55	549	26	17	20	243	124	10x M6	19	0,3
30x55	588	26	17	20	227	124	10x M6	19	0,3
32x60	752	26	17	20	255	136	12x M6	19	0,3
35x60	822	26	17	20	233	136	12x M6	19	0,3
38x65	1042	26	17	20	250	146	14x M6	19	0,35
40x65	1097	26	17	20	238	146	14x M6	19	0,35
42x75	1740	32	20	24	291	163	12x M8	42	0,55
45x75	1864	32	20	24	271	163	12x M8	42	0,55
48x80	1988	32	20	24	254	153	12x M8	42	0,6
50x80	2071	32	20	24	244	153	12x M8	42	0,6
55x85	2658	32	20	24	259	168	14x M8	42	0,6
60x90	2900	32	20	24	238	158	14x M8	42	0,65
65x95	3587	32	20	24	250	171	16x M8	42	0,7
70x110	5345	38	24	28	268	171	14x M10	83	1,25
75x115	5727	38	24	28	250	163	14x M10	83	1,35
80x120	6108	38	24	28	235	156	14x M10	83	1,4
85x125	7417	38	24	28	252	172	16x M10	83	1,45
90x130	7854	38	24	28	238	165	16x M10	83	1,55
95x135	9326	38	24	28	254	179	18x M10	83	1,6
100x145	11362	45	26	33	258	178	14x M12	145	2,1
110x155	12498	45	26	33	234	166	14x M12	145	2,25
120x165	15578	45	26	33	245	178	16x M12	145	2,45
130x180	21095	50	34	38	217	156	20x M12	145	3,5
140x190	24993	50	34	38	221	163	22x M12	145	3,85
150x200	29217	50	34	38	225	169	24x M12	145	4,1
160x210	33756	50	34	38	229	174	26x M12	145	5
170x225	39483	58	38	44	212	160	22x M14	255	5,5
180x235	45606	58	38	44	218	167	24x M14	255	6
190x250	56163	66	46	52	199	152	28x M14	255	8,3
200x260	63342	66	46	52	203	156	30x M14	255	8,7
220x285	81960	72	50	56	200	154	26x M16	360	11,2

Laufend aktualisierte Daten finden Sie auf unserer Homepage. For continuously updated data please refer to our website.

Technische Daten	Technical Data
TKN - Drehmoment	TKN - Torque
P <sub>w</sub> - Flächenpressung Welle	P <sub>w</sub> - Surface pressure shaft
P <sub>N</sub> - Flächenpressung Nabe	P <sub>N</sub> - Surface pressure hub
TA - Anzugs-Drehmoment der Schraube	TA - Installation torque per screw
M - Masse	M - Mass

Bestellbeispiel / order example	<b>WSR250</b>	<b>70</b>	<b>x</b>	<b>110</b>
Modell / model				
Ød				
ØD				

